

14 STAGE BINARY COUNTER/OSCILLATOR

- HIGH SPEED:
 $f_{MAX} = 65\text{MHz (TYP.) at } V_{CC} = 6\text{V}$
- LOW POWER DISSIPATION:
 $I_{CC} = 4\mu\text{A (MAX.) at } T_A = 25^\circ\text{C}$
- HIGH NOISE IMMUNITY:
 $V_{NIH} = V_{NIL} = 28\% V_{CC} \text{ (MIN.)}$
- SYMMETRICAL OUTPUT IMPEDANCE:
 $|I_{OH}| = I_{OL} = 4\text{mA (MIN)}$
- BALANCED PROPAGATION DELAYS:
 $t_{PLH} \cong t_{PHL}$
- WIDE OPERATING VOLTAGE RANGE:
 $V_{CC} \text{ (OPR)} = 2\text{V to } 6\text{V}$
- PIN AND FUNCTION COMPATIBLE WITH
 74 SERIES 4060

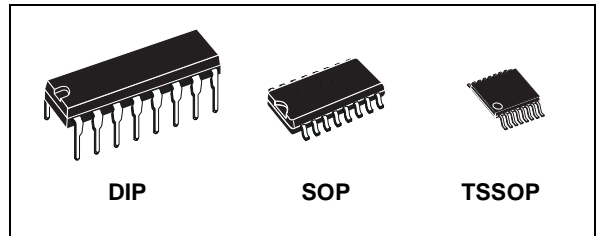

ORDER CODES

PACKAGE	TUBE	T & R
DIP	M74HC4060B1R	
SOP	M74HC4060M1R	M74HC4060RM13TR
TSSOP		M74HC4060TTR

DESCRIPTION

The M74HC4060 is an high speed CMOS 14-STAGE BINARY COUNTER/OSCILLATOR fabricated with silicon gate C²MOS technology. The oscillator configuration allows design of either RC or crystal oscillator circuits. A high level on the CLEAR accomplishes the reset function, i.e. all counter outputs are made low and the oscillator is disabled.

A negative transition on the clock input increments the counter. Ten kinds of divided output are provided; 4 to 10 and 12 to 14 stage inclusive. The maximum division available at Q12 is 1/16384 f oscillator.

The ϕ_1 input and the CLEAR input are equipped with protection circuits against static discharge and transient excess voltage.

PIN CONNECTION AND IEC LOGIC SYMBOLS

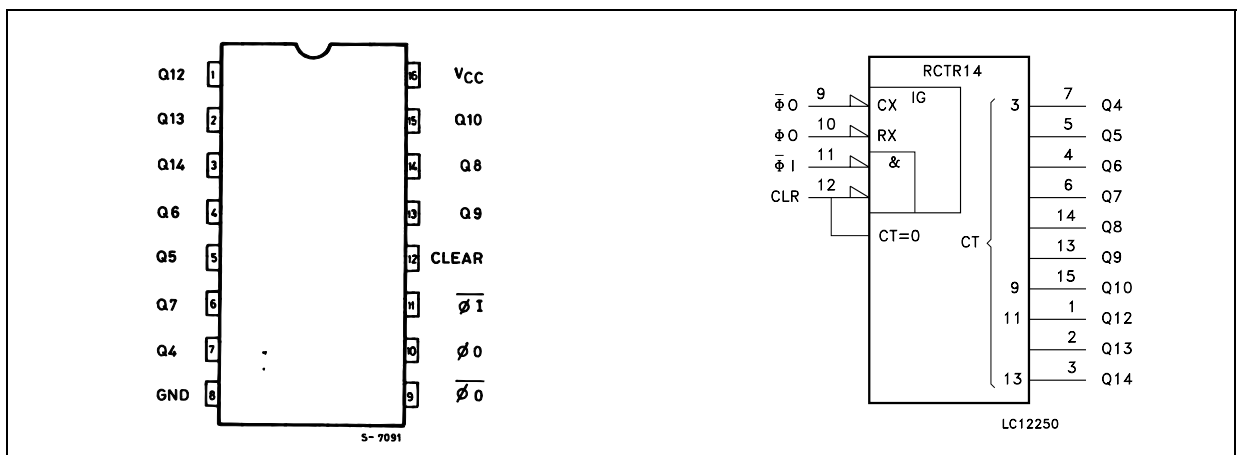

IINPUT AND OUTPUT EQUIVALENT CIRCUIT

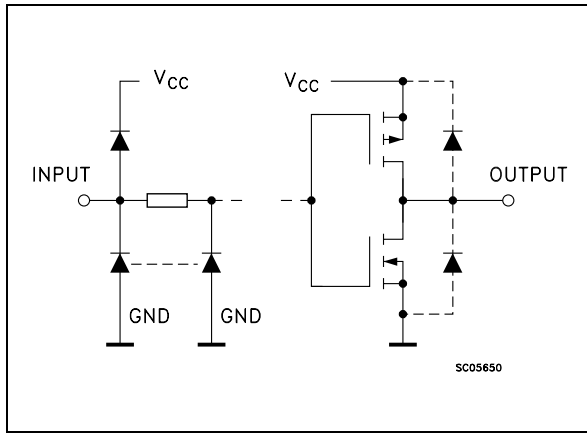

PIN DESCRIPTION

PIN No	SYMBOL	NAME AND FUNCTION
1, 2, 3	Q12 to Q14	Counter Outputs
7, 5, 4, 6, 14, 13, 15	Q4 to Q10	Counter Outputs
9	$\overline{\emptyset O}$	External Capacitor Connection
10	$\emptyset O$	External Resistor Connection
11	$\overline{\emptyset I}$	Clock Input / Oscillator Pin
12	CLEAR	Master Reset
8	GND	Ground (0V)
16	V _{CC}	Positive Supply Voltage

TRUTH TABLE

$\overline{\emptyset I}$	CLEAR	FUNCTION
X	H	COUNTER IS RESET TO ZERO STATE $\emptyset O$ OUTPUT GOES TO HIGH LEVEL $\overline{\emptyset O}$ OUTPUT GOES TO LOW LEVEL
	L	COUNT UP ONE STEP
	L	NO CHANGE

X : Don't Care

LOGIC DIAGRAM

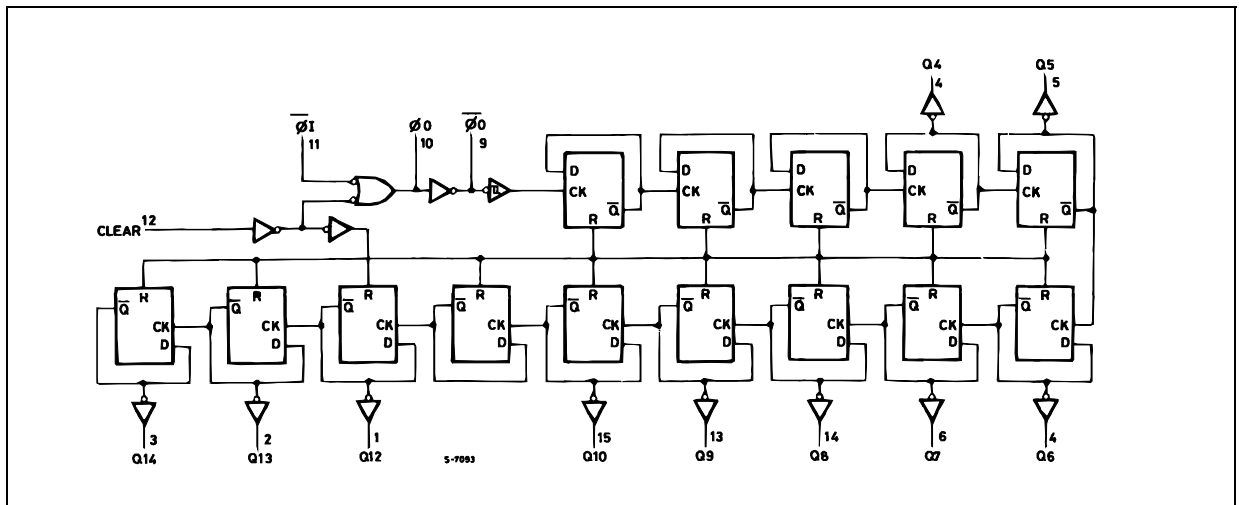

This logic diagram has not be used to estimate propagation delays

ABSOLUTE MAXIMUM RATINGS

Symbol	Parameter	Value	Unit
V_{CC}	Supply Voltage	-0.5 to +7	V
V_I	DC Input Voltage	-0.5 to $V_{CC} + 0.5$	V
V_O	DC Output Voltage	-0.5 to $V_{CC} + 0.5$	V
I_{IK}	DC Input Diode Current	± 20	mA
I_{OK}	DC Output Diode Current	± 20	mA
I_O	DC Output Current	± 25	mA
I_{CC} or I_{GND}	DC V_{CC} or Ground Current	± 50	mA
P_D	Power Dissipation	500(*)	mW
T_{stg}	Storage Temperature	-65 to +150	°C
T_L	Lead Temperature (10 sec)	300	°C

Absolute Maximum Ratings are those values beyond which damage to the device may occur. Functional operation under these conditions is not implied

(*) 500mW at 65 °C; derate to 300mW by 10mW/°C from 65°C to 85°C

RECOMMENDED OPERATING CONDITIONS

Symbol	Parameter	Value	Unit	
V_{CC}	Supply Voltage	2 to 6	V	
V_I	Input Voltage	0 to V_{CC}	V	
V_O	Output Voltage	0 to V_{CC}	V	
T_{op}	Operating Temperature	-55 to 125	°C	
t_r, t_f	Input Rise and Fall Time	$V_{CC} = 2.0V$	0 to 1000	ns
		$V_{CC} = 4.5V$	0 to 500	ns
		$V_{CC} = 6.0V$	0 to 400	ns

DC SPECIFICATIONS

Symbol	Parameter	Test Condition		Value						Unit	
		V _{CC} (V)		T _A = 25°C			-40 to 85°C		-55 to 125°C		
				Min.	Typ.	Max.	Min.	Max.	Min.		Max.
V _{IH}	High Level Input Voltage	2.0		1.5			1.5		1.5		V
		4.5		3.15			3.15		3.15		
		6.0		4.2			4.2		4.2		
V _{IL}	Low Level Input Voltage	2.0				0.5		0.5		0.5	V
		4.5				1.35		1.35		1.35	
		6.0				1.8		1.8		1.8	
V _{OH}	High Level Output Voltage (Q Output)	2.0	I _O =-20 μA	1.9	2.0		1.9		1.9		V
		4.5	I _O =-20 μA	4.4	4.5		4.4		4.4		
		6.0	I _O =-20 μA	5.9	6.0		5.9		5.9		
		4.5	I _O =-4.0 mA	4.18	4.31		4.13		4.10		
		6.0	I _O =-5.2 mA	5.68	5.8		5.63		5.60		
V _{OL}	Low Level Output Voltage (Q Output)	2.0	I _O =20 μA		0.0	0.1		0.1		0.1	V
		4.5	I _O =20 μA		0.0	0.1		0.1		0.1	
		6.0	I _O =20 μA		0.0	0.1		0.1		0.1	
		4.5	I _O =4.0 mA		0.17	0.26		0.33		0.40	
		6.0	I _O =5.2 mA		0.18	0.26		0.33		0.40	
V _{OH}	High Level Output Voltage (ØO, ØO Output)	2.0	I _O =-20 μA	1.8	2.0		1.8		1.8		V
		4.5	I _O =-20 μA	4.4	4.5		4.0		4.0		
		6.0	I _O =-20 μA	5.5	5.9		5.5		5.5		
V _{OL}	Low Level Output Voltage (ØO, ØO Output)	2.0	I _O =-20 μA		0.0	0.2		0.2		0.2	V
		4.5	I _O =-20 μA		0.0	0.5		0.5		0.5	
		6.0	I _O =-20 μA		0.1	0.5		0.5		0.5	
I _I	Input Leakage Current	6.0	V _I = V _{CC} or GND			± 0.1		± 1		± 1	μA
I _{CC}	Quiescent Supply Current	6.0	V _I = V _{CC} or GND			4		40		80	μA

AC ELECTRICAL CHARACTERISTICS ($C_L = 50$ pF, Input $t_r = t_f = 6$ ns)

Symbol	Parameter	Test Condition		Value						Unit	
		V_{CC} (V)		$T_A = 25^\circ\text{C}$			-40 to 85°C		-55 to 125°C		
				Min.	Typ.	Max.	Min.	Max.	Min.		Max.
t_{TLH} t_{THL}	Output Transition Time	2.0			30	75		95		110	ns
		4.5			8	15		19		22	
		6.0			7	13		16		19	
t_{PLH} t_{PHL}	Propagation Delay Time (\emptyset 1 - Q4)	2.0			170	300		375		450	ns
		4.5			41	60		75		90	
		6.0			30	51		64		76	
t_{PD}	Propagation Delay Time Difference ($Q_n - Q_{n+1}$)	2.0			32	75		95		110	ns
		4.5			7	15		19		22	
		6.0			5	13		16		19	
t_{PHL}	Propagation Delay Time (CLEAR - Q_n)	2.0			85	195		245		295	ns
		4.5			23	39		49		59	
		6.0			17	33		42		50	
f_{MAX}	Maximum Clock Frequency	2.0		6	12		5		4		MHz
		4.5		30	50		24		20		
		6.0		35	65		28		24		
$t_{W(H)}$ $t_{W(L)}$	Minimum Pulse Width (\emptyset 1)	2.0			30	75		95		110	ns
		4.5			8	15		19		22	
		6.0			7	13		16		19	
$t_{W(H)}$	Minimum Pulse Width (CLEAR)	2.0			30	75		95		110	ns
		4.5			8	15		19		22	
		6.0			7	13		16		19	
t_{REM}	Minimum Removal Time	2.0			40	100		125		150	ns
		4.5			10	20		25		30	
		6.0			9	17		21		26	

CAPACITIVE CHARACTERISTICS

Symbol	Parameter	Test Condition		Value						Unit	
		V_{CC} (V)		$T_A = 25^\circ\text{C}$			-40 to 85°C		-55 to 125°C		
				Min.	Typ.	Max.	Min.	Max.	Min.		Max.
C_{IN}	Input Capacitance	5.0			5	10		10		10	pF
C_{PD}	Power Dissipation Capacitance (note 1)	5.0			27						pF

1) C_{PD} is defined as the value of the IC's internal equivalent capacitance which is calculated from the operating current consumption without load. (Refer to Test Circuit). Average operating current can be obtained by the following equation. $I_{CC(opr)} = C_{PD} \times V_{CC} \times f_{IN} + I_{CC}$

TEST CIRCUIT

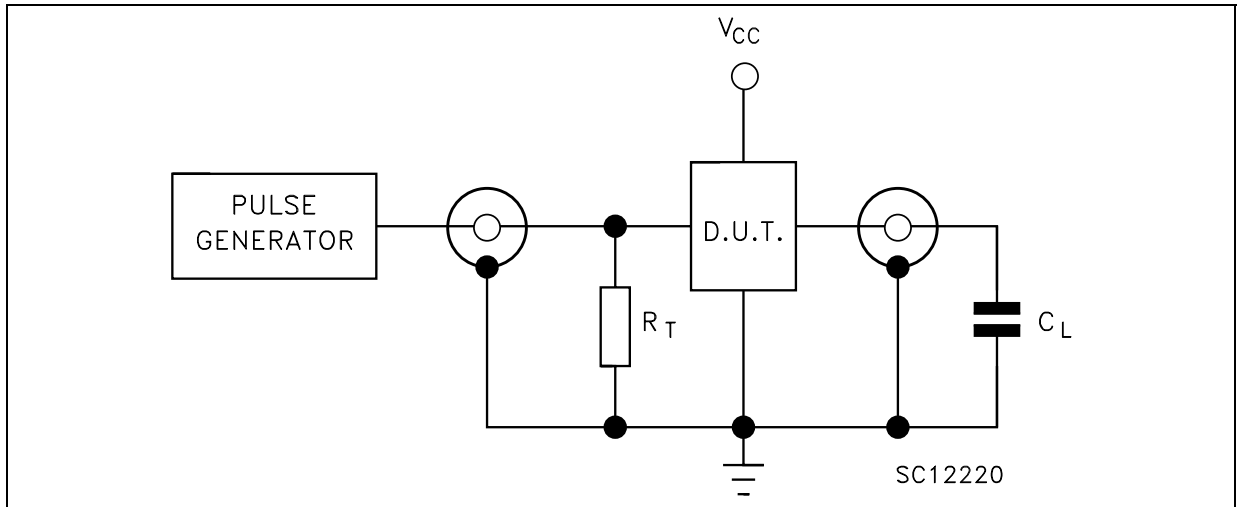

$C_L = 50\text{pF}$ or equivalent (includes jig and probe capacitance)
 $R_T = Z_{OUT}$ of pulse generator (typically 50Ω)

WAVEFORM 1: PROPAGATION DELAY TIMES, MINIMUM PULSE WIDTH ($\overline{\theta I}$) ($f=1\text{MHz}$; 50% duty cycle)

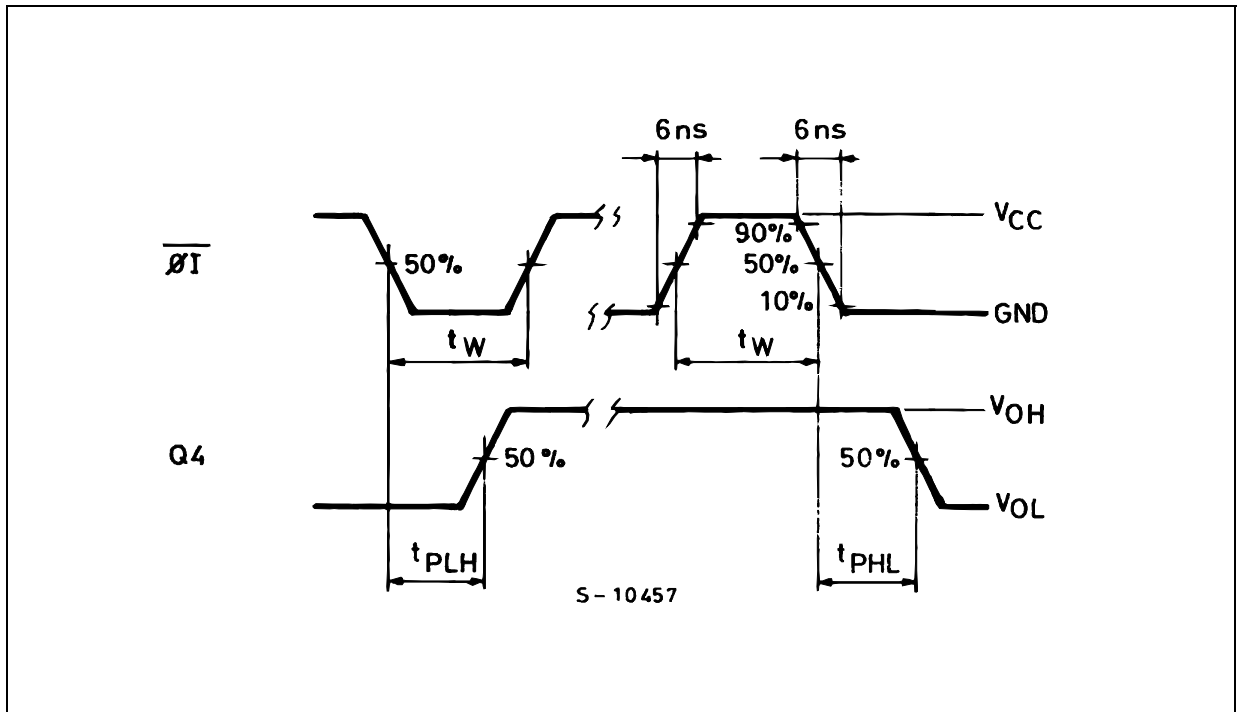

WAVEFORM 2 : PROPAGATION DELAY TIMES, MINIMUM PULSE WIDTH (CLEAR) (f=1MHz; 50% duty cycle)

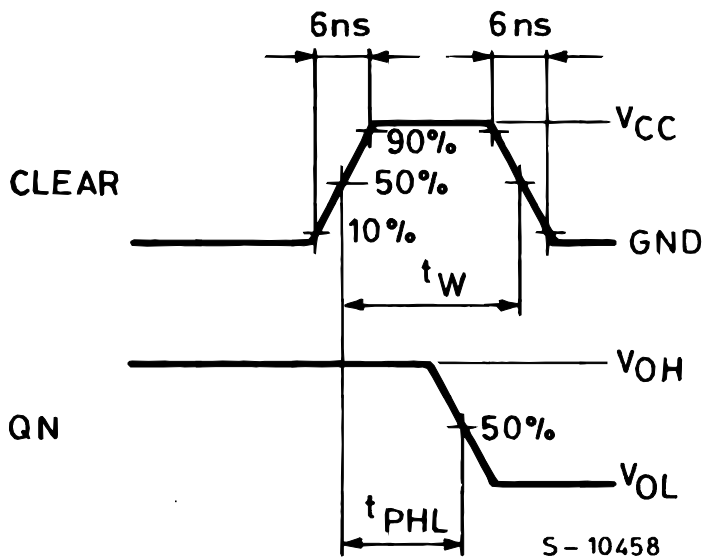

WAVEFORM 3 : PROPAGATION DELAY TIMES (f=1MHz; 50% duty cycle)

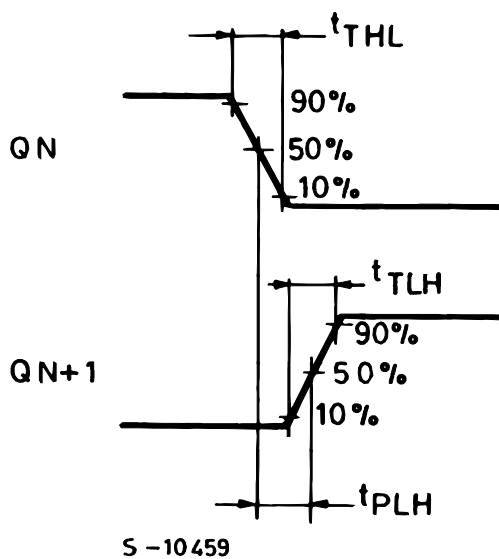

WAVEFORM 4 : PROPAGATION DELAY TIMES (f=1MHz; 50% duty cycle)

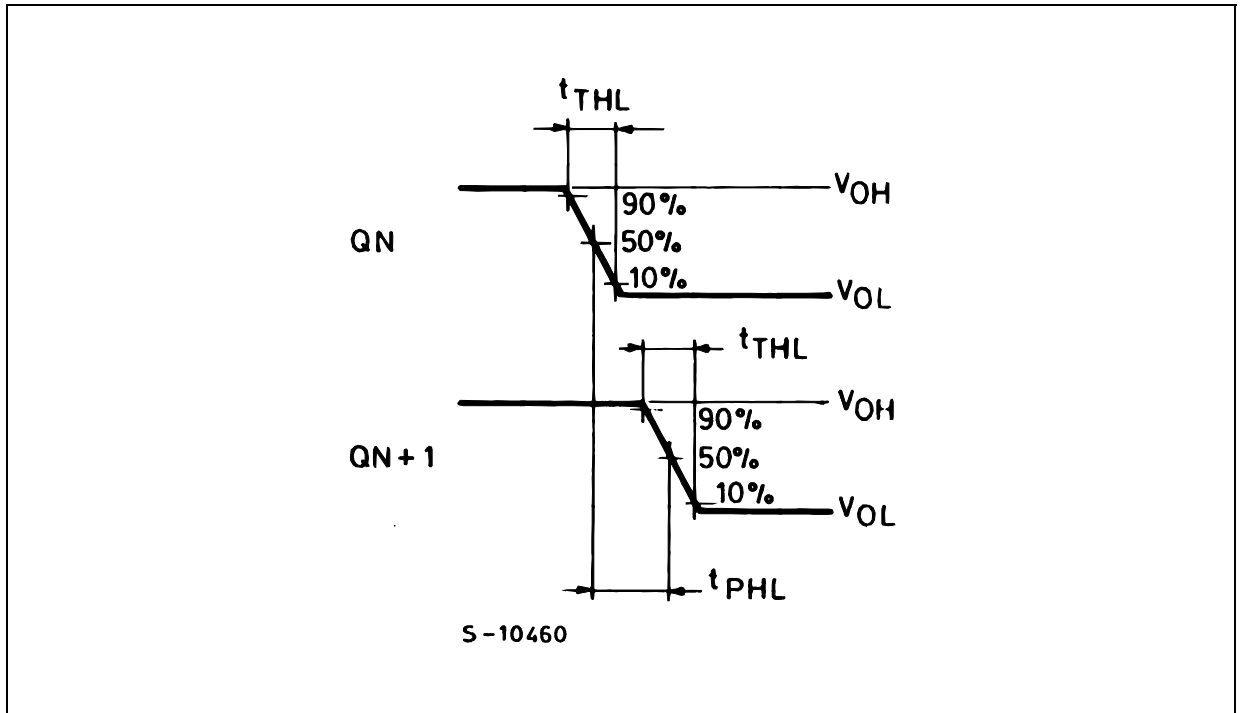

TYPICAL CLOCK DRIVE CIRCUITS

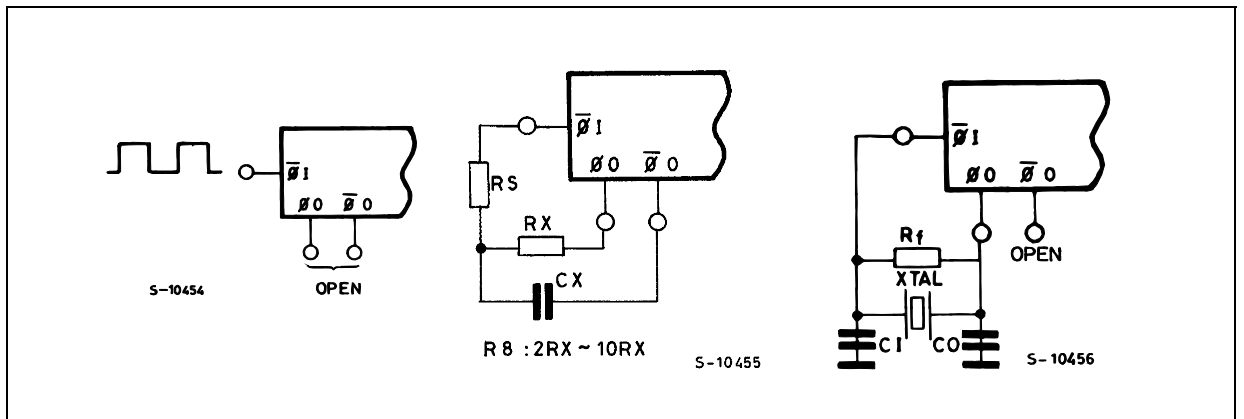

Plastic DIP-16 (0.25) MECHANICAL DATA

DIM.	mm.			inch		
	MIN.	TYP	MAX.	MIN.	TYP.	MAX.
a1	0.51			0.020		
B	0.77		1.65	0.030		0.065
b		0.5			0.020	
b1		0.25			0.010	
D			20			0.787
E		8.5			0.335	
e		2.54			0.100	
e3		17.78			0.700	
F			7.1			0.280
I			5.1			0.201
L		3.3			0.130	
Z			1.27			0.050

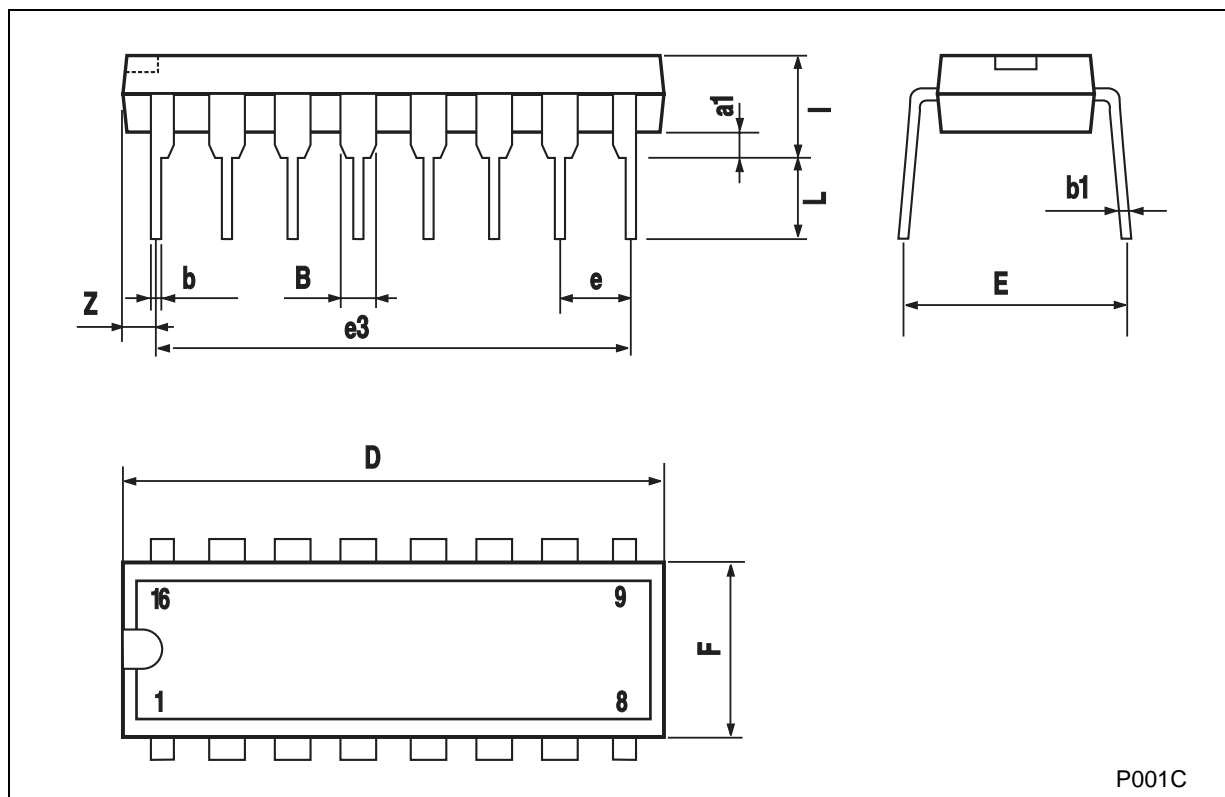

P001C

SO-16 MECHANICAL DATA

DIM.	mm.			inch		
	MIN.	TYP	MAX.	MIN.	TYP.	MAX.
A			1.75			0.068
a1	0.1		0.2	0.003		0.007
a2			1.65			0.064
b	0.35		0.46	0.013		0.018
b1	0.19		0.25	0.007		0.010
C		0.5			0.019	
c1	45° (typ.)					
D	9.8		10	0.385		0.393
E	5.8		6.2	0.228		0.244
e		1.27			0.050	
e3		8.89			0.350	
F	3.8		4.0	0.149		0.157
G	4.6		5.3	0.181		0.208
L	0.5		1.27	0.019		0.050
M			0.62			0.024
S	8° (max.)					

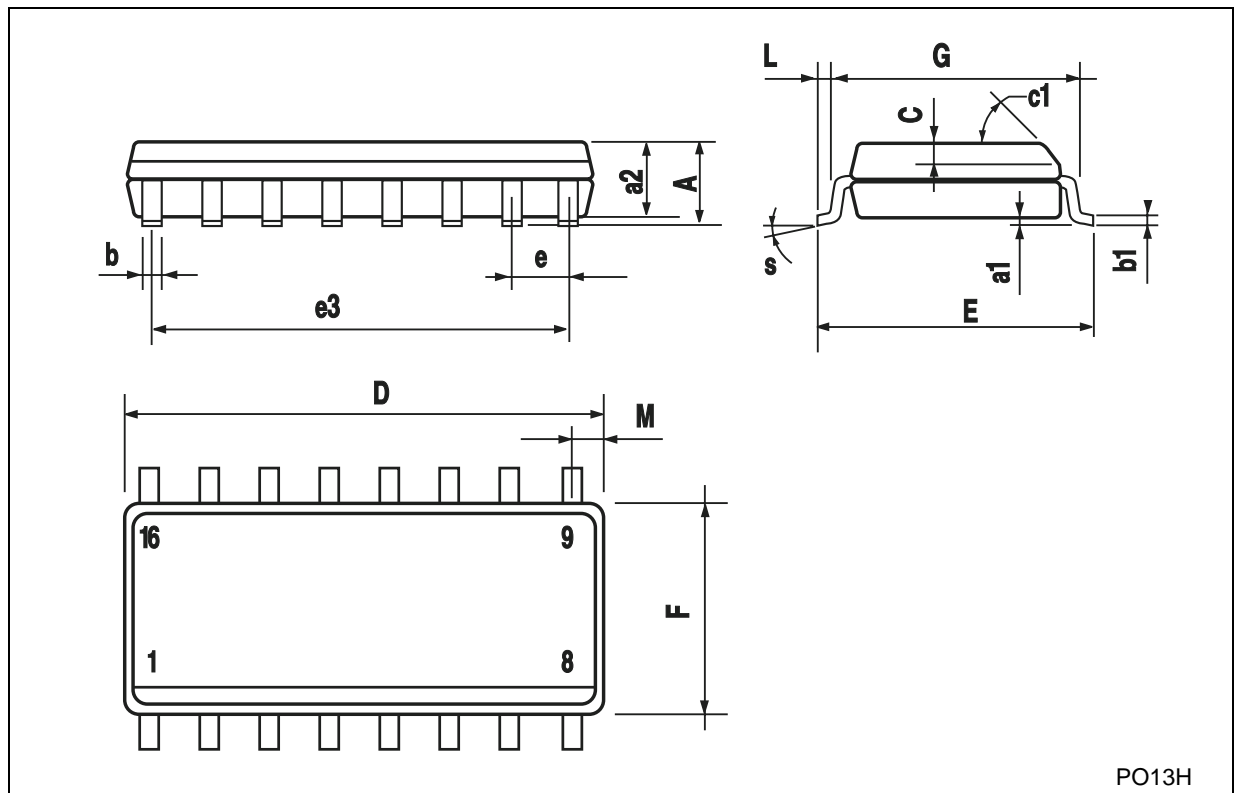

PO13H

TSSOP16 MECHANICAL DATA

DIM.	mm.			inch		
	MIN.	TYP	MAX.	MIN.	TYP.	MAX.
A			1.2			0.047
A1	0.05		0.15	0.002	0.004	0.006
A2	0.8	1	1.05	0.031	0.039	0.041
b	0.19		0.30	0.007		0.012
c	0.09		0.20	0.004		0.0089
D	4.9	5	5.1	0.193	0.197	0.201
E	6.2	6.4	6.6	0.244	0.252	0.260
E1	4.3	4.4	4.48	0.169	0.173	0.176
e		0.65 BSC			0.0256 BSC	
K	0°		8°	0°		8°
L	0.45	0.60	0.75	0.018	0.024	0.030

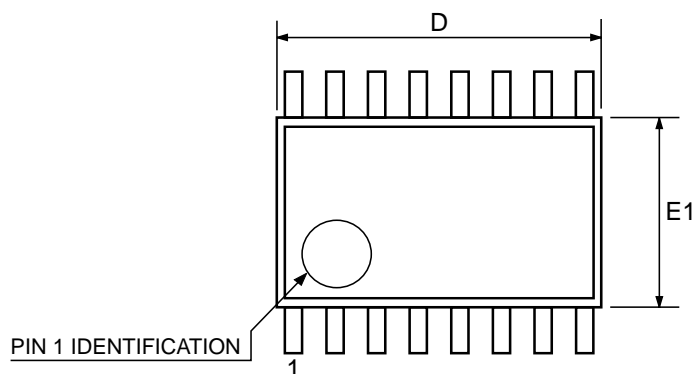
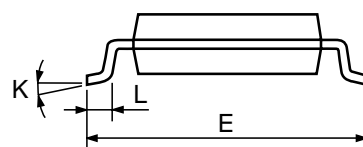
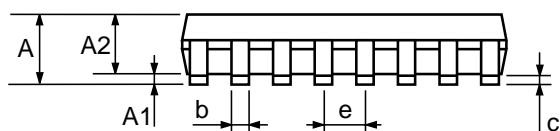

0080338D